

The logo features the text "Milieu Climate" in a bold, white, sans-serif font, centered on a dark blue background. A small registered trademark symbol (®) is positioned to the upper right of the word "Climate". Surrounding the text are seven solid-colored dots of varying sizes and colors: a pink dot at the top left, a light green dot at the top center, an orange dot at the top right, a yellow dot at the middle right, a teal dot at the bottom right, a light blue dot at the bottom center, and a peach dot at the bottom right.

Milieu Climate[®]

Welcome to **Milieu Climate**[®]

● MOTION

● HUMIDITY

● TEMPERATURE

● SOUND

Let's design your environment.

● AIR QUALITY

● PRESSURE

● LIGHTING



Congratulations
on choosing Milieu!

The Milieu Climate® is more than just a smart thermostat. It allows you to design your environment by controlling the room temperature and monitoring air quality, humidity, pressure, sound, lighting and motion.

With its built-in sensors and practical portability, you can maximise your comfort and your energy savings all in one step.

Please read the following manual carefully as it contains all necessary instructions needed to wire up and install your new thermostat.

Contents.

- 2 What can Milieu Climate do?
- 4 Hub — getting to know the features.
- 6 App — control from anywhere.
- 8 Safety information.
- 10 System compatibility.
- 12 What's in the box?
- 14 What your wire connections mean.
- 16 Cable labels.
- 18 Other things you might need.
- 20 Where to install?

22 Distance between Hub and Smart Base.

24 Have an Adapter Kit?

25 Let's get started!

28 Do you have a "C" wire?

31 Use your existing "C" wire.

45 Using a spare wire for the "C" wire.

59 No "C" wire or spare wire.

64 Troubleshooting.

66 Need more help?

68 Warranty.

What can Milieu Climate[®] do?

● TEMPERATURE

Control your environment with the perfect level of heating or cooling wherever you are in your home.

● AIR QUALITY

Monitor the health of your home and detect if the air quality in a room is poor, fair, good or great.

● HUMIDITY

Track humidity levels and use the Dry Mode to remove moisture and increase comfort.

● PRESSURE

Identify pressure levels in your home and surroundings with the Milieu Climate's[®] barometric sensor.

● SOUND

Monitor the sound levels in your room for ultimate relaxation and concentration.

● LIGHTING

Identify ideal lighting levels for your day-to-day activities and know when lights have been left on.

● MOTION

Improve energy efficiency with the Milieu Climate's® motion sensors. It detects if someone is in the room or not and adjusts the temperature accordingly.

● ENERGY SAVINGS

Get the right amount of heating or cooling wherever you are in your home to conserve energy.

● MOBILE APPLICATION

Control your environment anywhere, anytime using the Apple or Android mobile app. Use voice control with Google Assistant or Amazon Alexa.

Getting to know the features.

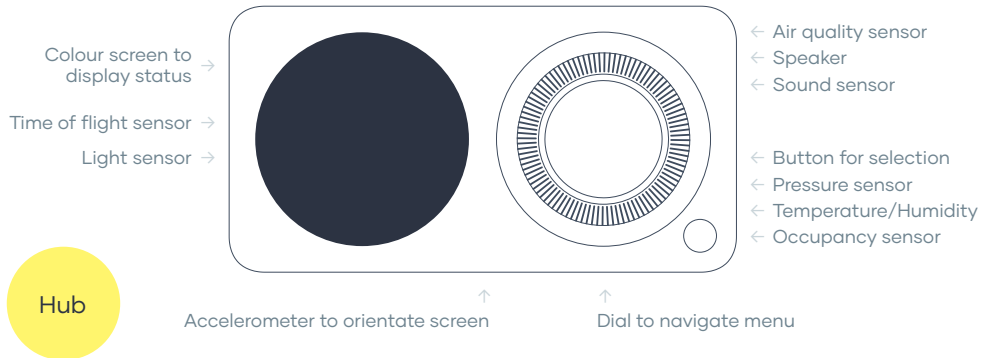

Button

- Move through AC modes
- Select and start Pairing mode
- Select and start Override mode

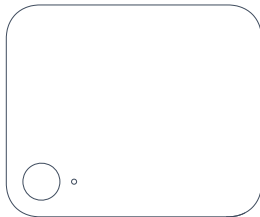

LED to display status

- White is off
- Blue is cooling
- Red is heating
- Purple is auto heat/cool
- Green is fan
- Yellow is dry

Smart
Base

App — control from anywhere.



The Milieu app allows you to control your environment at any time, from anywhere.

With the app you can manage multiple Hubs, and multiple locations. Hubs can be grouped together under properties, and you can switch between Hubs for easy control of all of your climate systems in one place.

Key features.

Climate Control

The climate control gives you complete control of your system.

Change operating mode and target temperature with the cool, heat, dry, fan only and auto options.

Environmental Display

The environmental display shows real-time sensor readings.

Timers and Schedules

One-off timers can be set to change the system's operating mode for up to 24 hours.

Advanced schedule allows you to program the Hub to automatically set the system mode, fan option, and temperature at specific times throughout the day. A different schedule can be set for each day of the week.

Safety information.

WARNING

Please read the safety information carefully before installing the thermostat to your Heating, Ventilation, and Air Conditioning (HVAC) system. Improper installation may result in electric shocks or fire.

WARNING: RISK OF ELECTRIC SHOCK

If you come across mains voltage wiring, professional installation required.
Always perform installation work with the power shut-off.
Touching energised electric parts can cause an electric shock.

Follow the relevant local and national codes and regulations when installing the thermostat. Use a qualified installer, if required, for working on high voltage. Make sure connections are properly secured and wiring is as per local codes. Use only with compatible systems. Use with incompatible systems can cause damage to the thermostat and fire.

This is a 24VAC device. Do not use on voltages greater than 30VAC.

This device has magnets. It may effect electronic devices, e.g. data storage media, hearing aids or devices that can be affected by the magnets.

Do not disassemble or try to repair the thermostat. Do no short across thermostat terminals to check equipment working. This can damage the thermostat and void warranty. Use the security screw to mount the Hub securely, if required by local codes.

System compatibility.

Follow this guide if you have a 24VAC (non-communicating) system. If you have a communicating system, follow the "Installation Guide" available in the Adapter Kit.

Milieu Climate® works with 24VAC heating and cooling systems including gas, electric, oil systems, add-on cooling systems and heat pumps (forced air) with/without auxiliary and emergency heating.

For more information, visit milieulabs.com.au
or email us at support@milieulabs.com.au

WORKS WITH:

- + Non-communicating (24VAC control) — Brand Adapter Kit NOT required
- + Most US and Australian 24VAC systems
- + Heating: 1 and 2 stage
- + Cooling: 1 and 2 stage
- + Gas heating with add on cooling systems: 1 and 2 stage
- + Heat pump: 1 and 2 stage with auxiliary, with O/B
- + Power: 1 and 2 transformers (heating and cooling transformers)
- + Systems with and without C wire (use Power Base)

WITH ADAPTER KIT:

- + Communicating systems
- + Most Japanese, Korean and Chinese systems

NOT WITH:

- × Hydronic systems
- × Boiler systems
- × 240VAC systems*
- × Dual Fuel systems**

*These systems may work with the addition of a 240v to 24v relay. See website or contact Milieu Labs for more detail.

**Duel fuel — gas heating combined with heat pump.

What's in the box?

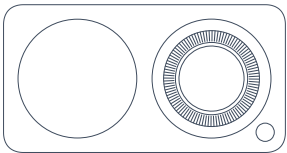

Hub

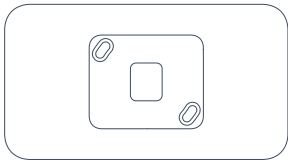

Trim Plate

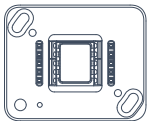

Smart Base



Smart Base Cover

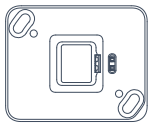

Power Base



Power Base Cover

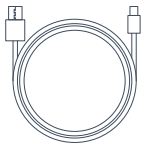

USB-C Cable



Solid Core Wires 8



Wire Connectors 8

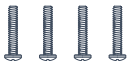

Mounting Screws 4

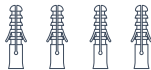

Wall Anchor 4



Security Screw

What your wire connections mean.

	485 Data +	B
	485 Data -	A
	Fan relay	G
Second stage cooling (conventional) Second stage heating/cooling (heat pump)		Y₂
First stage cooling (conventional) First stage heating/cooling (heat pump)		Y₁
Future use for accessories/options		□
	24VAC power (always required)	RC

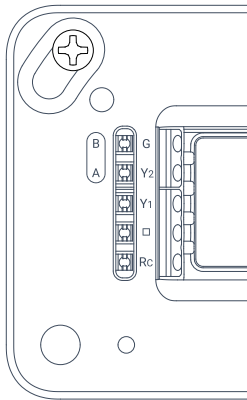

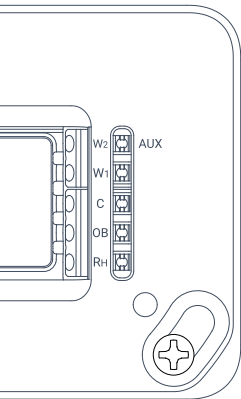

W₂ Second stage heating (conventional)

AUX Aux heating (heat pump)

W₁ First stage heating (conventional)

C 24VAC common (always required)

Heat pump reversing valve

OB O setting — on during cooling

B setting — on during heating

RH 24VAC heat transformer

Only used when there are two transformers

Cable labels.

A

A

G

G

W₁

W₁

B

B

Y₁

Y₁

W₂ | AUX

W₂ | AUX

C

C

Y₂

Y₂

RC

RC

□

□

OB

OB

RH

RH

A A

G G

W₁ W₁

B B

Y₁ Y₁

W₂ | AUX W₂ | AUX

C C

Y₂ Y₂

RC RC

□ □

OB OB

RH RH

Other things you might need.

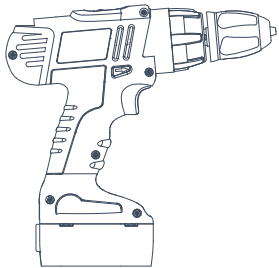

Drill

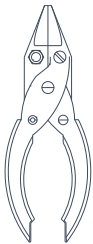

Parallel Pliers

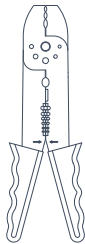

Wire Strippers



Screwdriver



Pencil

Where to install?

If this is a new installation, select a location with good air circulation.

Do not install near doors, windows or areas with high draught.

Do not install in direct sunlight.

If you are replacing an existing thermostat you may want to select a new location.

You can use the Power Base to install the thermostat at a new location, still using the old location and wiring for the Smart Base.

If you are installing at the same location as your old thermostat, you can reuse existing wiring.

You may need to run new wiring depending on the type of install you had.

The Hub can be installed vertically or horizontally. The screen will automatically rotate.

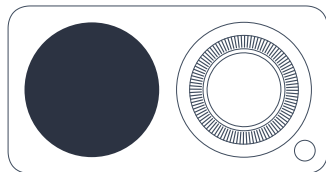
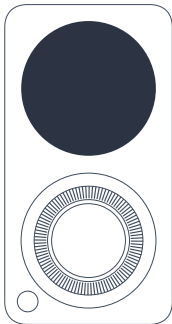

HINT: make sure the Smart Base is mounted for the orientation you'd like to use.

Distance between Hub and Smart Base.

To ensure there is a good wireless connection between the Hub and the Smart Base, make sure the distance between the two is not more than 10m. The presence of walls and objects can affect the performance of the connection between the devices.

If you are using the thermostat away from the Smart Base, make sure it has enough battery power or is connected to a USB charger.

The Hub can be used on battery power for up to 30 minutes, depending on the usage.

**SMART BASE
WITH COVER**



HUB

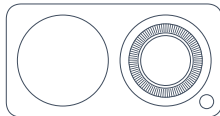

10m maximum for best wireless connection

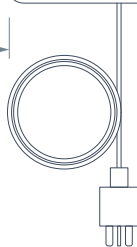

WALL PLUG
(Not provided)



Have an Adapter Kit?

If so, please follow the instructions
in your Adapter Kit instead.

Otherwise →



Adapter Kits are not required for 24VAC systems.





Let's get started!

Please follow these instructions
to install your new Milieu Climate®
Smart Thermostat.

Switch off power.

For safety and security please switch off the power to your HVAC system.

This can be done through the master switch on your HVAC system or your circuit breaker box.

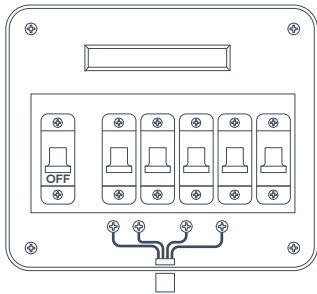
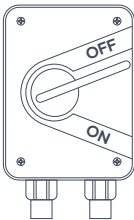

Remove old cover.

Remove the cover off your old thermostat. Keep the wires connected for now.

Some covers will pop off while others might require you to unscrew them. Please refer to the instructions for your old thermostat.

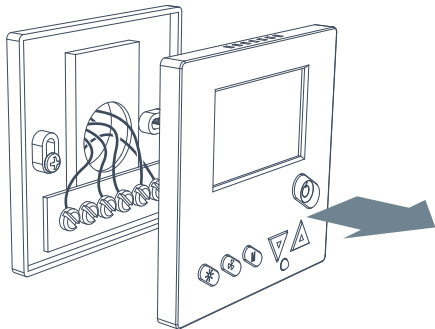

Do you have a "C" wire?

Please check if you have a "C" wire connected. Your new thermostat will need one.

This should be labeled "C" on the wire terminals and is typically a blue or black wire.



Yes, I have a "C" wire.
Continue to **next page**

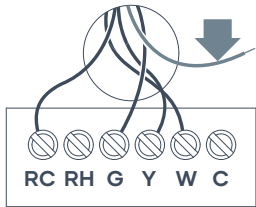

No "C" wire, but I have a spare wire.

Go to **page 45**



No "C" wire and no spare wire.

Go to **page 59**

Use your existing "C" wire.

Please follow these instructions for using your existing "C" wire with your new thermostat.

Your wire connections.

Take a picture of the wire connections on your old thermostat.

Use this for reference when you reconnect the wires to your new thermostat.

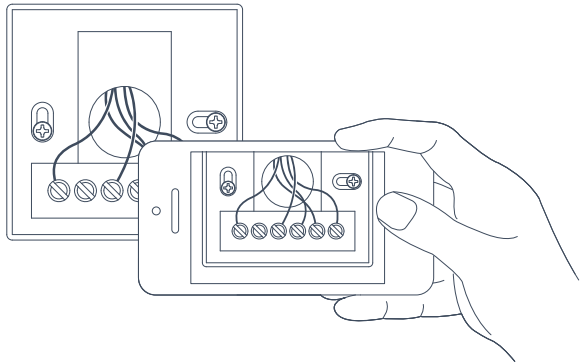

Label wires.

With the wires still connected, use the labels provided on page 16 to label the wires on your old thermostat.

If you have jumper wires connected, don't worry about them as they won't be needed.

These labels will be useful for reference when reconnecting them to your new thermostat.

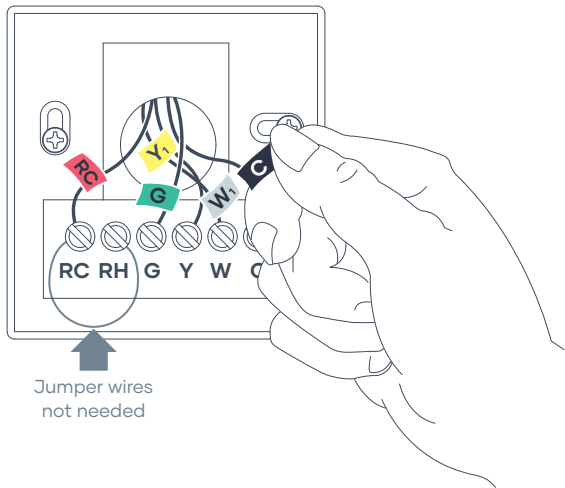

Remove old thermostat.

Disconnect the wires and remove your old thermostat base from the wall.

Again, don't worry about the jumper wires. Remove them along with the old thermostat.

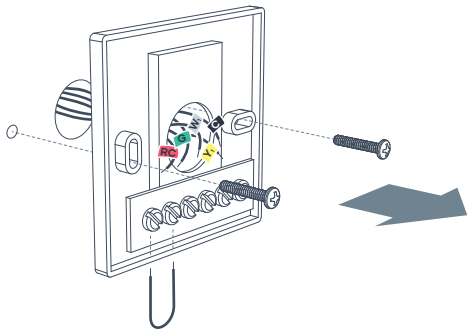

Prepare to install your Smart Base.

Use the Smart Base to mark positions for screws on the wall.

You can use a bubble level to make sure Smart Base is level.

Depending on your wall material, a drill might be needed to secure your wall anchors.

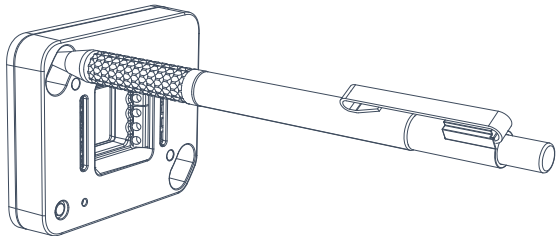

Using the Trim Plate?

You might want to use the Trim Plate to cover up the holes in your wall from the old thermostat.

If so, place it on the wall first and screw the Smart Base over the top of the Trim Plate.

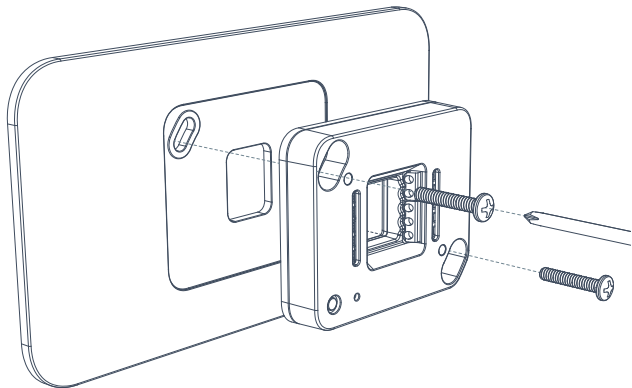

Screw in your Smart Base.

Bring the wires through the centre opening in the Smart Base and attach the Smart Base to the wall using the supplied screws.

Again, depending on your wall material you may want to use the supplied wall anchors as well.

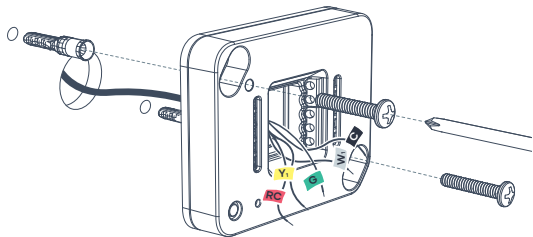

Connect wires.

Connect the wires to the Smart Base terminals, matching them with the labeled wires.

NOTE: The Smart Base has magnets so it might pull your metal tools towards it – that's normal.

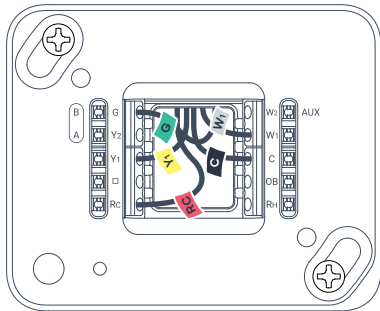

Bulging wires?

Carefully push any excess, bulging wires back through the hole so that they are not sticking out past the Smart Base.

NOTE: The Hub will be placed over the Smart Base. Any wires sticking out might prevent the Hub from powering up.

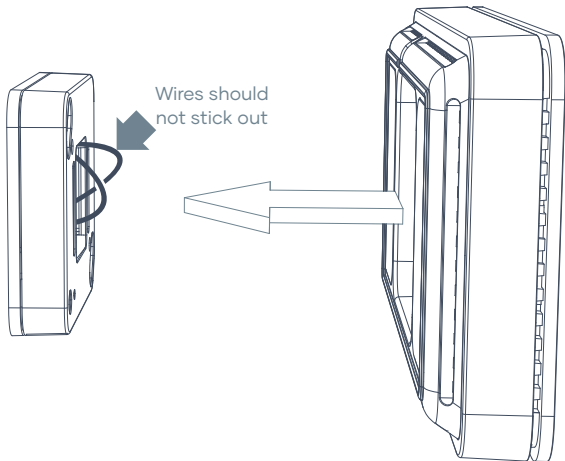

Attach the Hub.

Place the Hub on the Smart Base. This can be placed with the screen on the left or on the right; as you like.

The Hub will magnetically attach to the Smart Base. If needed, you can also secure the Hub with the supplied security screw.

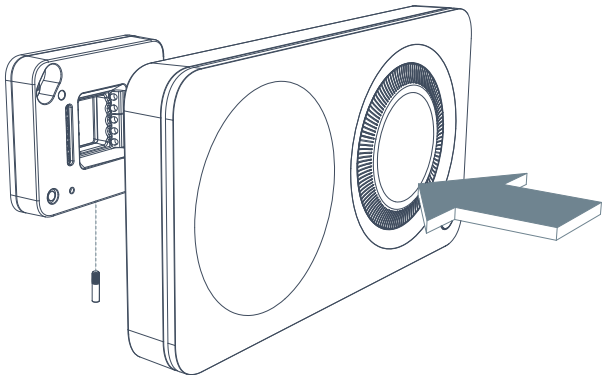

Switch the power back on.

You can now switch the power back on to your HVAC system.

This can be done through the master switch on your HVAC system or your circuit breaker box.

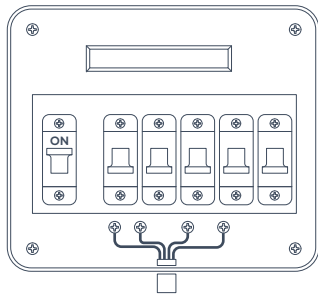
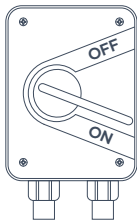

Power on!

Congratulations!
You just installed your
new Milieu Climate[®]
Smart Thermostat.

Press and hold the front
button to power the unit on.

Please follow the
on-screen instructions
to set up your device.

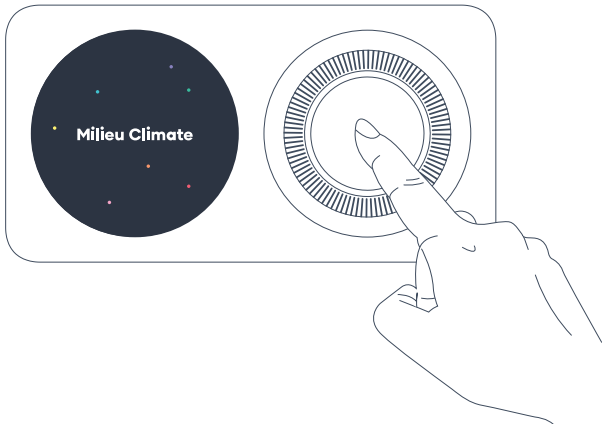

Using a spare wire for the "C" wire.

Please follow these instructions for using use your spare wire as a "C" wire for your new thermostat.

Label wires.

Use the sticky labels provided on page 16 to label your spare wire as the "C" wire.

Label the other wires as they are connected on your old thermostat.

If you have jumper wires connected, don't worry about them as they won't be needed.

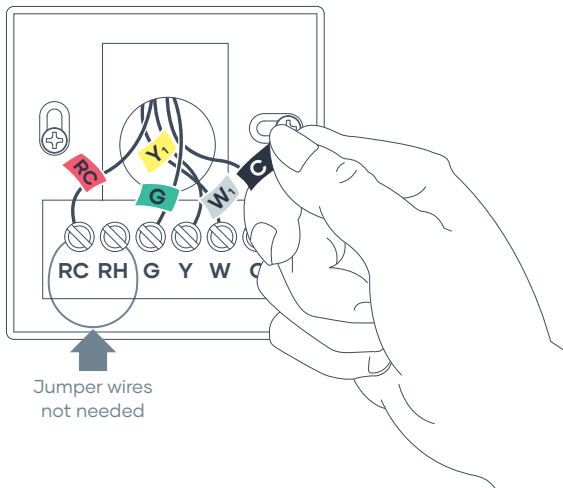

Remove your old thermostat.

Disconnect the wires and remove your old thermostat base from the wall.

Again, don't worry about the jumper wires. Remove them along with the old thermostat.

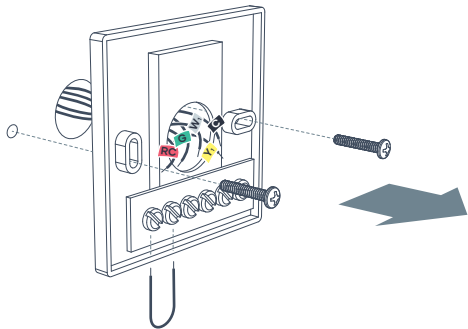

Prepare to install your Smart Base.

Use the Smart Base to mark positions for screws, on the wall.

You can use a bubble level to make sure Smart Base is level.

Depending on your wall material, a drill might be needed to secure your wall anchors.

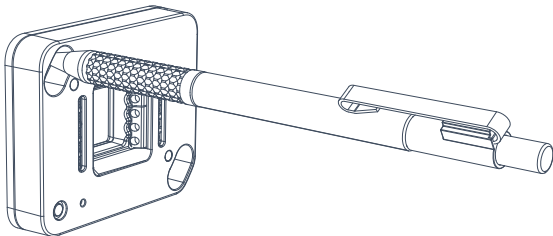

Using the Trim Plate?

You might want to use the Trim Plate to cover up the holes in your wall from the old thermostat.

If so, place it on the wall first and screw the Smart Base over the top of the Trim Plate.

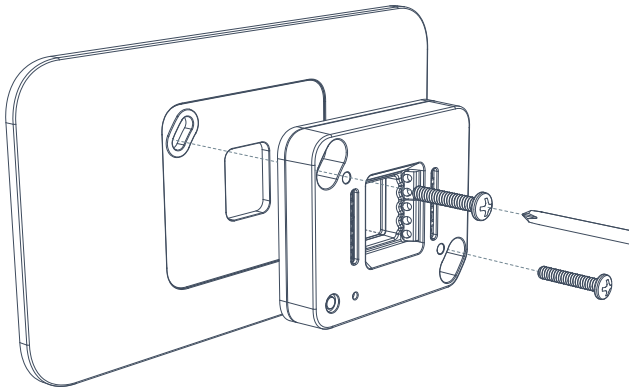

Screw in your Smart Base.

Bring the wires through the centre opening in the Smart Base and attach the Smart Base to the wall using the supplied screws.

Again, depending on your wall material you may want to use the supplied wall anchors as well.

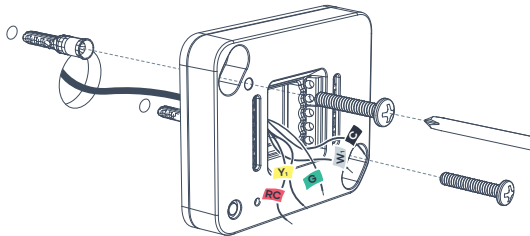

Connect wires.

Connect the wires to the Smart Base terminals, matching them with the labeled wires.

NOTE: The Smart Base has magnets so it might pull your metal tools towards it – that's normal.

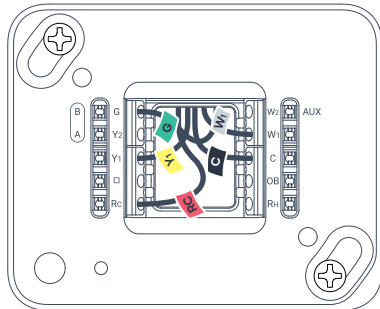

Bulging wires?

Carefully push any bulging, excess wires back through the hole so that they are not sticking out past the Smart Base.

NOTE: The Hub will be placed over the Smart Base. Any wires sticking out might prevent the Hub from powering up.

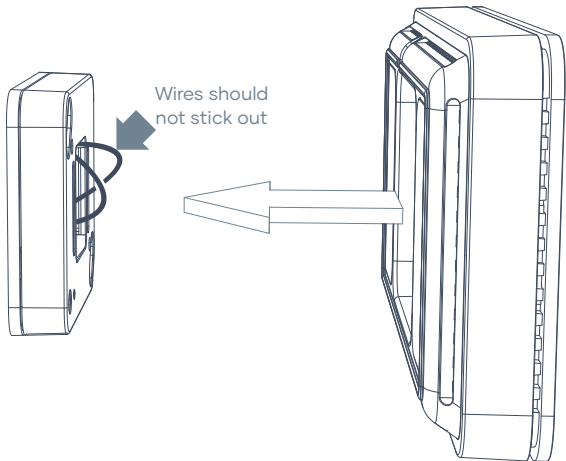

Attach the Hub.

Place the Hub on the Smart Base. This can be placed with the screen on the left or on the right; as you like.

The Hub will be magnetically attached to the Smart Base. If needed you can also secure the Hub with the supplied security screw.

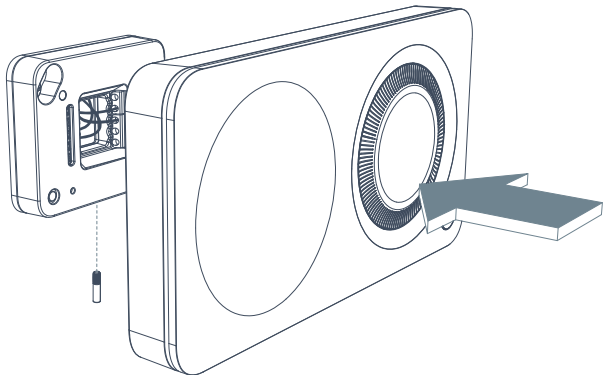

Go to your HVAC system.

Go to your HVAC system and open the access panel to the electronics board.

NOTE: Always turn the power off to the equipment and follow the manufactures safety instructions before removing the access panel.

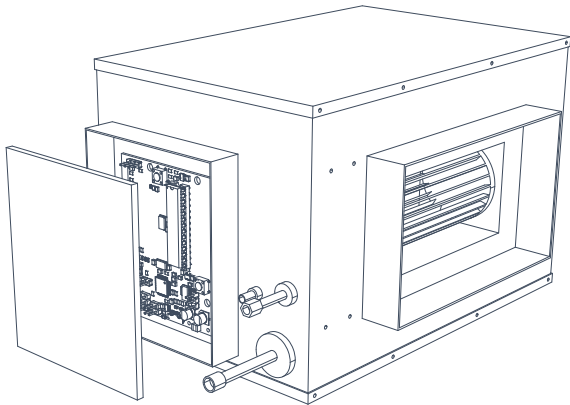

Connection of spare wire.

Locate the spare wire that was used for the "C" wire connection to your Smart Base.

Connect it to the "C" terminal on the indoor unit board.

Close the door panel when finished.

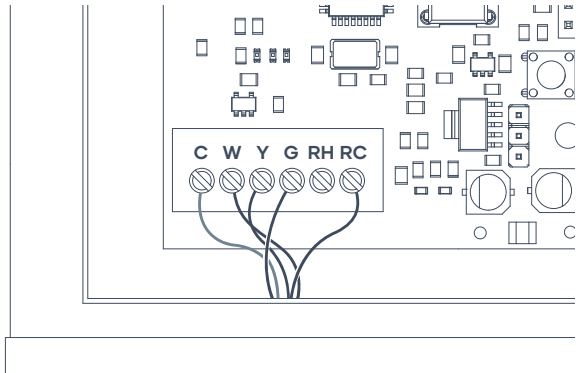

Switch the power back on.

You can now switch the power back on to your HVAC system.

This can be done through the master switch on your HVAC system or your circuit breaker box.

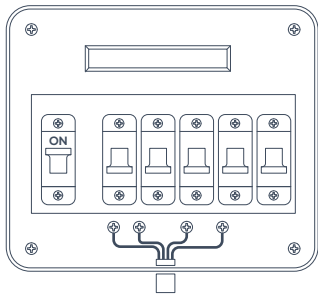
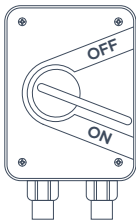

Power on!

Congratulations!
You just installed your
new Milieu Climate®
Smart Thermostat.

Press and hold the front
button to power the unit on.

Please follow the
on-screen instructions
to set up your device.

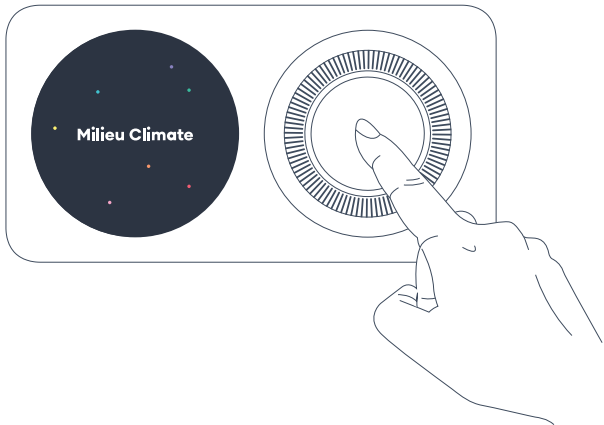



No "C" wire or spare wire.

You will need to run additional wires or contact our Support team for other options.

Go to **page 67**.

Heat/cool conventional system.

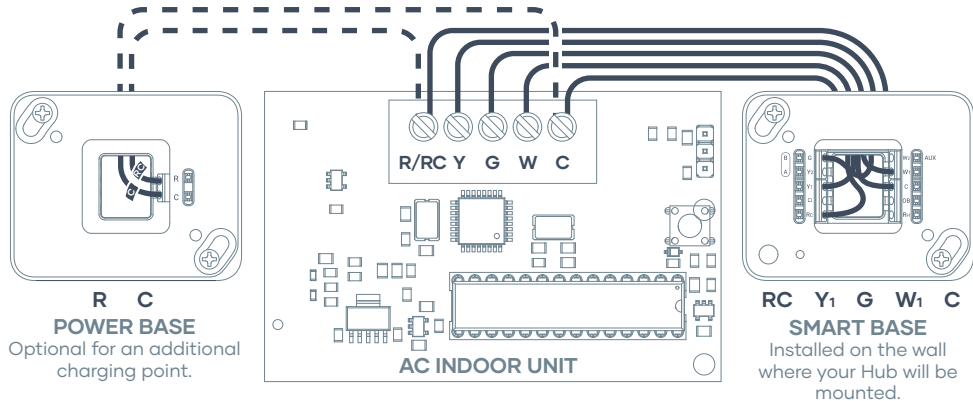

Heat pump system.

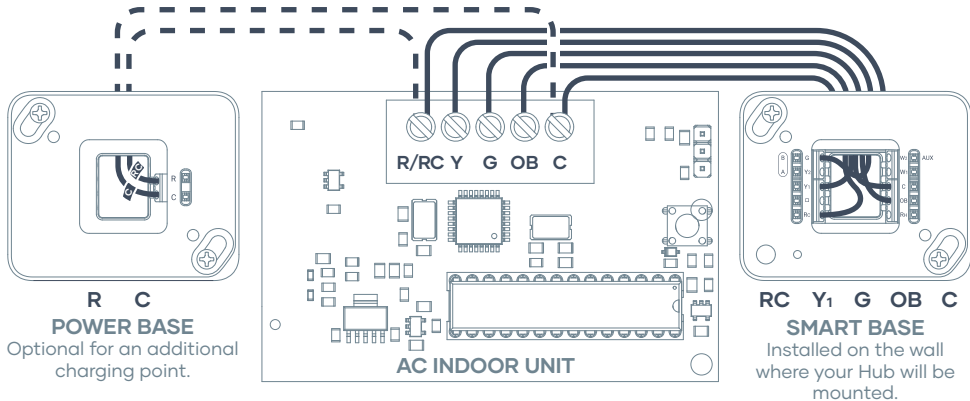

Gas system.

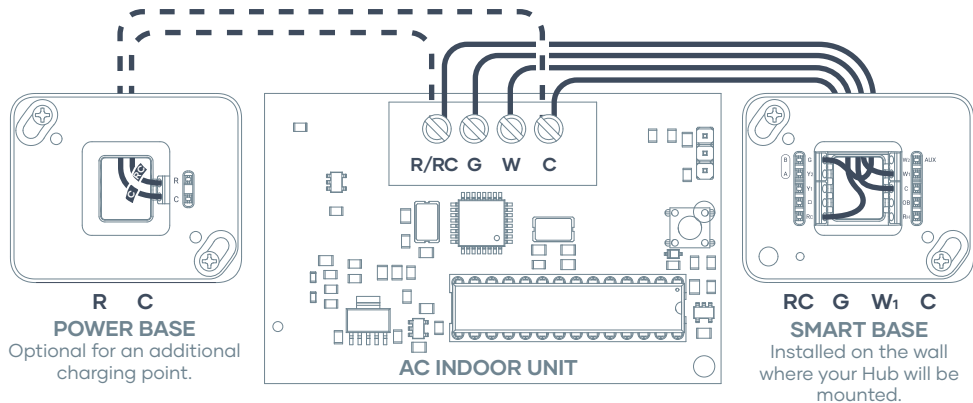

Troubleshooting.

Reboot the Hub and Smart Base

- a. Hub – press and hold button for 10 seconds
- b. Smart Base – press and hold button for 10 seconds

Wi-Fi

- a. Does not connect – try restarting your router

Hub does not power up

- a. Check the Smart Base LED is on
- b. Check that the wires are inserted correctly into the Smart Base
- c. Try powering the Hub with the USB-C cable

System does not start in the selected mode

- a. Check Smart Base LED is the correct colour for the mode you want
- b. Check Smart Base modes change when you change modes on the Hub

- c. If modes do not sync between Hub and Smart Base:
 - check the connection by going to Settings > Technical
 - find "Thread", it should say connected
 - if "Thread" says disconnected then try rebooting the Hub/Smart Base by pressing and holding the button for 10 seconds

Mobile IOS and Android App

- a. If your app says, property or Hub/Smart Base not found, wait 5 minutes
- b. Quit app and reopen
- c. If your app settings are not applied to the Hub:
 - Check Internet connection on the Hub Technical page

- Go to Settings > Wi-Fi and check you are connected to your router or go to Settings > Technical and check that "Is Cloud Connected" says yes
- If "Is Cloud Connected" says no, try either rebooting the Hub or restarting your router

Need more help?

Visit milieulabs.com.au

Email support@milieulabs.com.au

Call [+61 2 9659 7438](tel:+61296597438)

Warranty.

This Milieu Labs® manufacturer warranty (the Warranty) is granted by Tronac Pty Ltd (ACN 155 469 015) trading as Milieu Labs® (“Milieu Labs”) to “You”, the purchaser of the newly manufactured Milieu Climate® Smart Thermostat (the Product), subject to the following terms and conditions. Services provided under this Warranty will be rendered by Milieu Labs® accredited Service Agents and Repair Centres.

Warranty period of the Product

This warranty applies to the Milieu Climate® Smart Thermostat parts (not labour) for a period of 2 years from the date of purchase (Warranty Period). If proof of purchase cannot be provided, the manufacture date of the Product will be considered as the date of purchase.

By purchasing and/or using the Product, you agree, in addition to this Warranty, to comply with the terms of our Terms and Conditions, as updated from time to time (the **Terms**). A copy of our Terms and Conditions may be found here: www.milieulabs.com.au/terms.

In the event of any inconsistency between this Warranty and the Terms, the Terms prevail to the extent of such inconsistency.

Statutory Guarantees

Milieu Labs® goods come with guarantees that cannot be excluded under the Australian Consumer Law.

You are also entitled to choose a refund or replacement for major failures with goods.

If a failure with the goods does not amount to a major failure, you are entitled to have the failure rectified in a reasonable time. If this is not done, you are entitled to a refund for the goods and obtain a refund of any unused portion.

You can find more information about the Australian Consumer Law on the ACCC website: accc.gov.au (see under "For Consumers" tab).

Milieu Labs® Pty Ltd offers this Warranty in conjunction with any guarantees imposed by the Australian Consumer Law.

General

Milieu Labs® warrants the Product to be free from defects in workmanship and materials for the Warranty Period. The Warranty does not cover bundled accessories, which were delivered together with the Product such as: cables, etc. If the Product fails during normal and proper use within the Warranty Period,

Milieu Labs® will repair or replace the defective parts of the Product, or the Product itself, with new or reconditioned parts or products that are functionally equivalent or superior to those originally supplied.

This Warranty applies only if the Product was newly manufactured on the date of purchase and in respect of claims by the original purchaser. Please keep the original purchase invoice and this warranty card for future service request.

This Warranty does not include failure caused by improper installation, operation, cleaning or maintenance, accident, damage, misuse, abuse, non-Milieu Labs® modifications to the product, normal wear and tear or any other event, act, default or omission outside Milieu Labs' control.

All components repaired or replaced by a Milieu Labs® accredited Repair Centre will be under warranty for the remaining period of Warranty, or for no less than 3 months.

If the Product is under Warranty, You hereby agree to transfer the ownership of replaced defective parts and such parts shall automatically become the property of Milieu Labs®.

Customer Responsibility

When using the Product

- Read the user manual first and use the Product only according to the user manual.
- Keep the original packaging in case the Product needs to be returned for repair, original packaging provides a better protection for the Product during transportation.
- Please check the manual and Milieu Labs® support website for predefined solutions, before contacting the customer service.

When contacting Milieu Labs® Customer Service

- Before contacting Milieu Labs® technical support, ensure that You have the Product in front of You and that it is turned on, if feasible. Please also be ready to provide the Product's serial number, the model name and proof of purchase.
- Technical support hotline phone number can be found in the 'Need more help?' section of this booklet.

- You will be required on request of Milieu Labs® to support with troubleshooting of the Product, which may include for example below types of actions:
 - Running diagnostic tools and programs on the Product
 - Performing other reasonable activities requested by Milieu Labs®, which will assist in identifying or resolving the problems.
- If the problem is not solved remotely, Milieu Labs® will issue a RMA number for Your Product. Please record Your RMA Number for service case tracking purposes.
- Describe the problem clearly and completely on the RMA request form.
- Enclose a copy of this completed warranty card and a copy of Your sales invoice/receipt detailing the purchase of your Product. (Please note: Milieu Labs® reserves the right to request the original documents.) If You do not provide the requested documents for warranty validation, then the manufacture date of the Product as recorded by Milieu Labs® will be deemed to be the date of purchase.
- Pack the Product with its original packaging. The original packaging will provide better protection for the Product during delivery. If the Product is not packaged properly in its original box, Milieu Labs® will not be liable for any damage occurred during transit. Please do not send in anything but the Product itself unless specially requested by Milieu Labs®. Please remove any accessories from the Product. Milieu Labs® shall have no liability for the loss, damage or destruction of accessories unless they are caused by wilful or gross negligent acts by Milieu Labs®.

Exclusions from this limited Warranty

Milieu Labs® does not warrant uninterrupted or error-free operation of this Product. The warranty only covers technical hardware issues during the Warranty Period and in normal use conditions.

It does not apply to customer induced damages or circumstances such as but not limited to:

- the Product has been tampered, repaired and/or modified by non-authorized personnel;
- the serial number of the Product, components or accessories has been altered, cancelled or removed;
- the warranty seals have been broken or altered;
- obsolescence;
- damage (accidental or other) to the Product that is cosmetic, meaning damage that does not impact the operation and functioning of the Product, such as without limitation to rust, change in colour, texture or finish, wear and tear, gradual deterioration;
- damage to the Product caused by war, terrorism, fire, accident, natural disaster, intentional or accidental misuse, abuse, neglect or improper maintenance, use under abnormal conditions;
- damage to the Product caused by improper installation or improper connection;
- damage to the Product caused by an external electrical fault or any accident;
- damage to the Product resulting from use outside of the operation or storage parameters or environment detailed in the User's Manual;

- Un-usability of or damage to the Product caused by contamination with hazardous substances, diseases, vermin or radiation.
- fraud, theft, unexplained disappearance or wilful act;

Except as provided in this warranty and to the maximum extent permitted by law, Milieu Labs® is not responsible for direct, special, incidental or consequential damages resulting from any breach of warranty or condition, or under any other legal theory, including but not limited to loss of use; loss of revenue; loss of actual or anticipated profits (including loss of profits on contracts); loss of the use of money; loss of anticipated savings; loss of

business; loss of opportunity; loss of goodwill; loss of reputation; loss of, damage to or corruption of data; or any indirect or consequential loss or damage whatsoever caused including the replacement of equipment and property, any costs of recovering or reproducing any data stored on or used with the Product. The foregoing limitation shall not apply to death or personal injury claims, or any statutory liability for intentional and gross negligent acts and/or omissions by Milieu Labs®. Some jurisdictions do not allow the exclusion or limitation of incidental or consequential damages; to the extent such jurisdiction is governing this Warranty the above limitations do not apply to You.

Out of Warranty Cases:

Returning the Product to the Milieu Labs® Repair Centre during the Warranty Period does not automatically mean that it will be repaired free of charge. Upon receiving Your Product, Milieu Labs® reserves the right to check the validity of Your Warranty and Your request for Warranty service.

If Your service request is found to be out of Warranty a Service Charge List with an offer for repair will be provided to You. You have the right to accept or reject the repair offer.

If You accept the repair, we will invoice You for the repair labour, spare parts and other costs stated in the Service Charge List. You must pay the invoice within 4 weeks of the date of issue of the invoice.

In the event that You returned the Product to the Milieu Labs® Repair Centre and Your Product is out of Warranty and You reject the repair, we reserve the right to invoice You with the handling and storage costs.

The Product will only be returned after receiving the invoiced amounts from You.

If You do not pay the invoice by the due date, and the invoice amount exceeds the remaining value of the Product, You agree to transfer the ownership of the Product to Milieu Labs® in order to settle the invoice.

Making a Warranty Claim

To make a claim You can do one of the following things:

- contact our team by telephone on +61 2 9659 7438; or
- contact our team by email at support@milieulabs.com.au; or
- visit Your retailer (place of purchase) and lodge the claim personally with retail staff.

When You lodge Your claim, You should provide a full description of the Product and the reason for the claim.

Once You have lodged Your claim, we will ask You to return the Product. To return the Product, You can do one of the following things:

- return the Product to Your retailer (place of purchase); or
- arrange for the Product to be delivered to Milieu Labs® (at Your own expense).

You will need to present Your receipt as proof of purchase in order to make a claim under the Warranty. You can do this by:

- emailing a copy of the receipt to us at support@milieulabs.com.au or
- including a copy of the receipt with the Product if it is delivered to Milieu Labs® for repair; or
- providing a copy to Milieu Labs® Service Centre staff if You return Your Product to us.

We will then assess Your claim and notify You whether it is covered under the Warranty. The decision whether to repair or replace a Product is at our sole discretion unless there is a "major failure" as defined in the Australian Consumer Law.

If the claim is approved, we will deliver the repaired or replaced Product back to You at our own cost. You will need to provide us with Your contact details so that we can return the Product to You.

If the claim is rejected and we determine the Product is not covered under the Warranty, we will deliver the Product back to You. This will be at Your expense. If Your claim is not covered, Milieu Labs® will offer to repair the Product at Your expense.

Please note that our delivery is limited to areas within Australia that are accessible by mail carriers. For more information please contact our team on +61 2 9659 7438.



EUROTEC

People • Technology • Solutions

HEAD OFFICE : AUCKLAND Tel : (09) 579 1990
WELLINGTON : Tel : (04) 499 3591 CHRISTCHURCH : Tel : (03) 366 0017
Email : sales@eurotec.co.nz WEBSITE : www.eurotec.co.nz

HVAC • Refrigeration • Electrical • Measurement

Milieu Climate[®] is a product designed by **Milieu Labs**[®] in Sydney, Australia.

© Copyright **Milieu Labs**[®]. All rights reserved.

JUNE 2022 / MCUG100-3